

PCB e-Learning Platform

**PCB ELIMINATION
PART II: ESTABLISHED AND EMERGING
TECHNOLOGIES**

OVERVIEW OF TECHNOLOGIES

As of now, there exists a plethora of high-efficiency technologies for the elimination of PCBs that have been developed.

These established or emerging technologies are either **destructive** or **non-destructive**, which include both **thermal** and **non-thermal** procedures.

THIS MODULE PROVIDES
DESCRIPTIONS FOR BOTH
ESTABLISHED AND EMERGING
TECHNOLOGIES.

TECHNOLOGIES

Established technologies

- High Temperature Incineration (HTI)
- Plasma Arc
- Dechlorination (BCD)
- Autoclave
- In-situ Vitrification (ISV)
- ECO Logic Process
- PCB Gone

Emerging technologies

- Bioremediation
- Solidification and Stabilization
- Chemical oxidation
- Electrochemical oxidation

OVERVIEW OF TECHNOLOGIES

Stockholm Convention, Article 6(1)(d)(ii) reads:

“... PCB is “irreversibly” destroyed or transformed or its content is low, taking into account applicable rules, standards, and guidelines.”

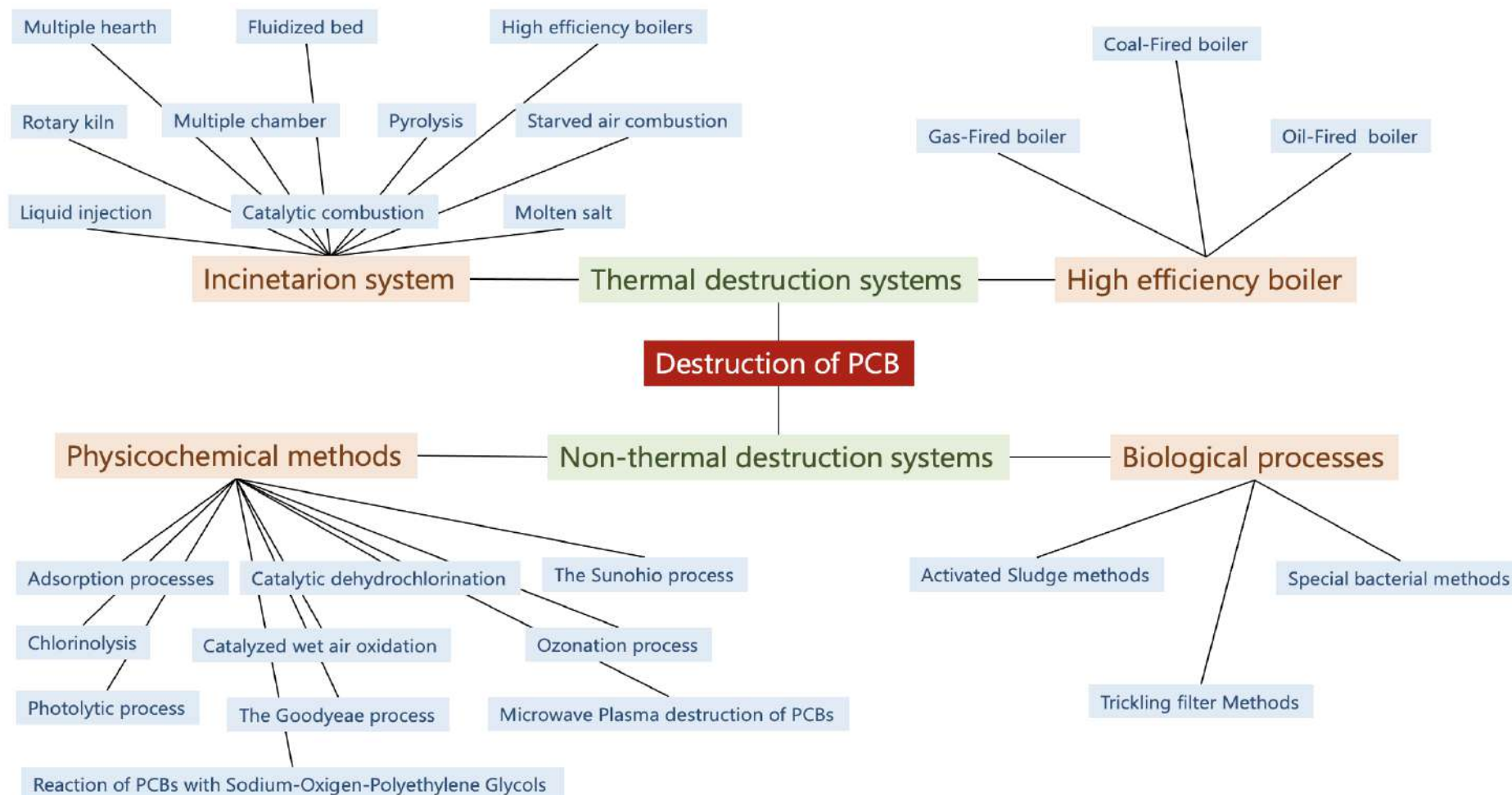

OVERVIEW OF TECHNOLOGIES

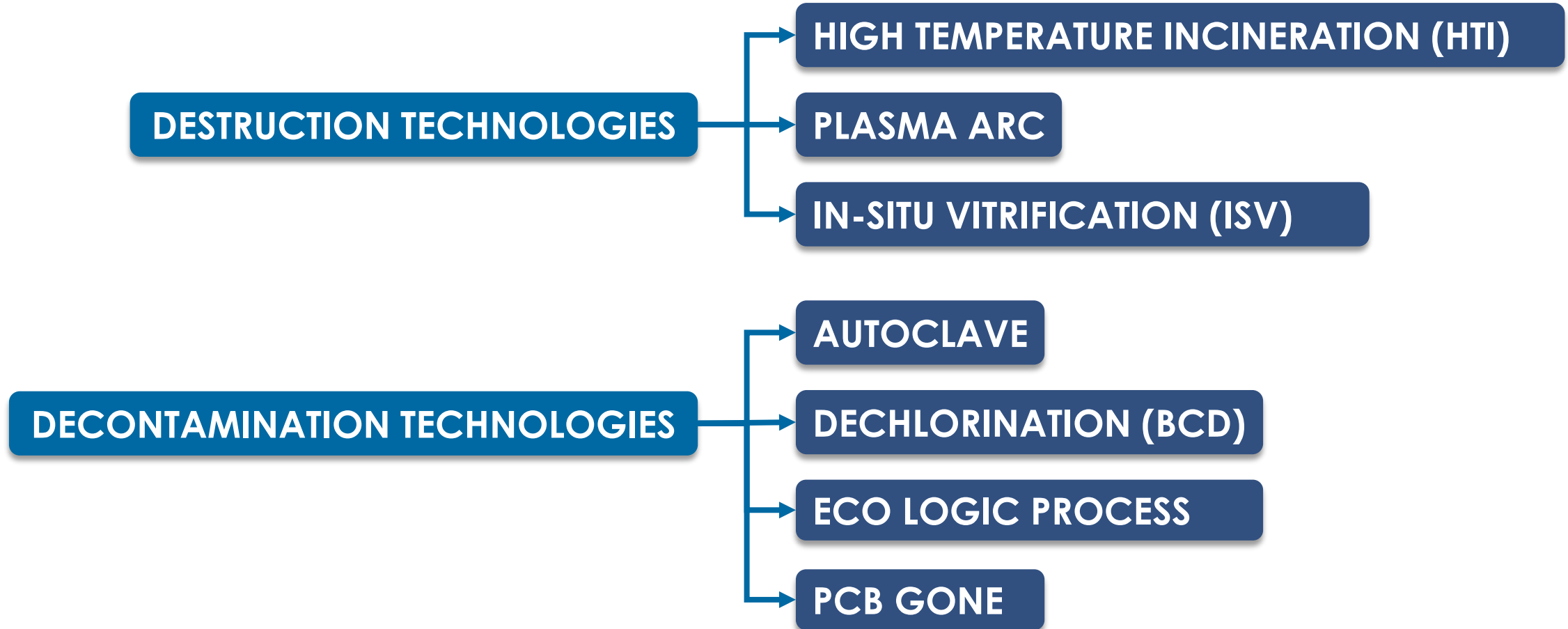

DESTRUCTION PROCESSES – HIGH TEMPERATURE INCINERATION (HTI)

HIGH TEMPERATURE INCINERATION (HTI)

- Hazardous waste incineration uses controlled flame combustion to destroy PCBs.
- Requires good control of Time, Temperature and Turbulence (The 3 T's).
- Temperatures reach up to 850 °C for 2-3 seconds for PCB destruction.
- Possible for large capacities.
- Located in developed countries (at least 8-9 operational plants across Europe – 2025).
- High yields of PCB destruction (99.9999%)
- High Destruction and Removal Efficiency (DRE)
- Medium operation expenses.



Source:
<https://43rhm92nktag49ay632wnmbt-wpengine.netdna-ssl.com/wp-content/uploads/2016/07/incineration-services.jpg>

DESTRUCTION PROCESSES – HIGH TEMPERATURE INCINERATION (HTI)

HIGH TEMPERATURE INCINERATION (HTI)

Advantages

- Total destruction
- Well-established technology due to experience
- Controllable exhaust gas emissions
- Price stability.
- Targets: liquids (even high PCB grade) and capacitors

Disadvantages

- Formation of dioxins and furans
- High operation costs.
- Transboundary movement if there is no local capacity.
- Lack of flexibility.
- Impacting costs on packaging for small amount delivered.

PCDDs.

TABLE 1. OPERATIONAL DATA FROM PCB TESTS AT ROLLINS ENVIRONMENTAL SERVICES (12)

	Test		
	1, Fuel Oil	2, Fluff	3, Whole Capacitors
O ₂ , %	10.1	9.8	10.1
CO ₂ , %	9.1	8.8	5.0
CO, ppm			
Fuel Oil Feed, l/hr	2088	2411	2300
PCB Waste Feed, kg/hr*	--	61	104
Kiln Flame, °C	1306	1252	1338
Liquid Burner Flame, °C	1485	1499	1509
Afterburner, °C	1308	1331	1332
Hot Zone, °C	1091	1089	1096
Residence Time, sec.	--	3.2	3.0
Scrubber Water, l/min	3200	3200	3200
Lime Slurry Feed, l/min [†]	6.4	6.4	8.4

* Fluff was 29% PCBs, fluff feed rate was 210 kg/hr, fluff plus fiber drum feed rate was 330 kg/hr. Whole capacitor feed rate was 360 kg/hr.
[†] Approximately 30% by weight of lime.

HIGH TEMPERATURE INCINERATION PLANT – LAY OUT 1

Example: Incineration plant in Finland

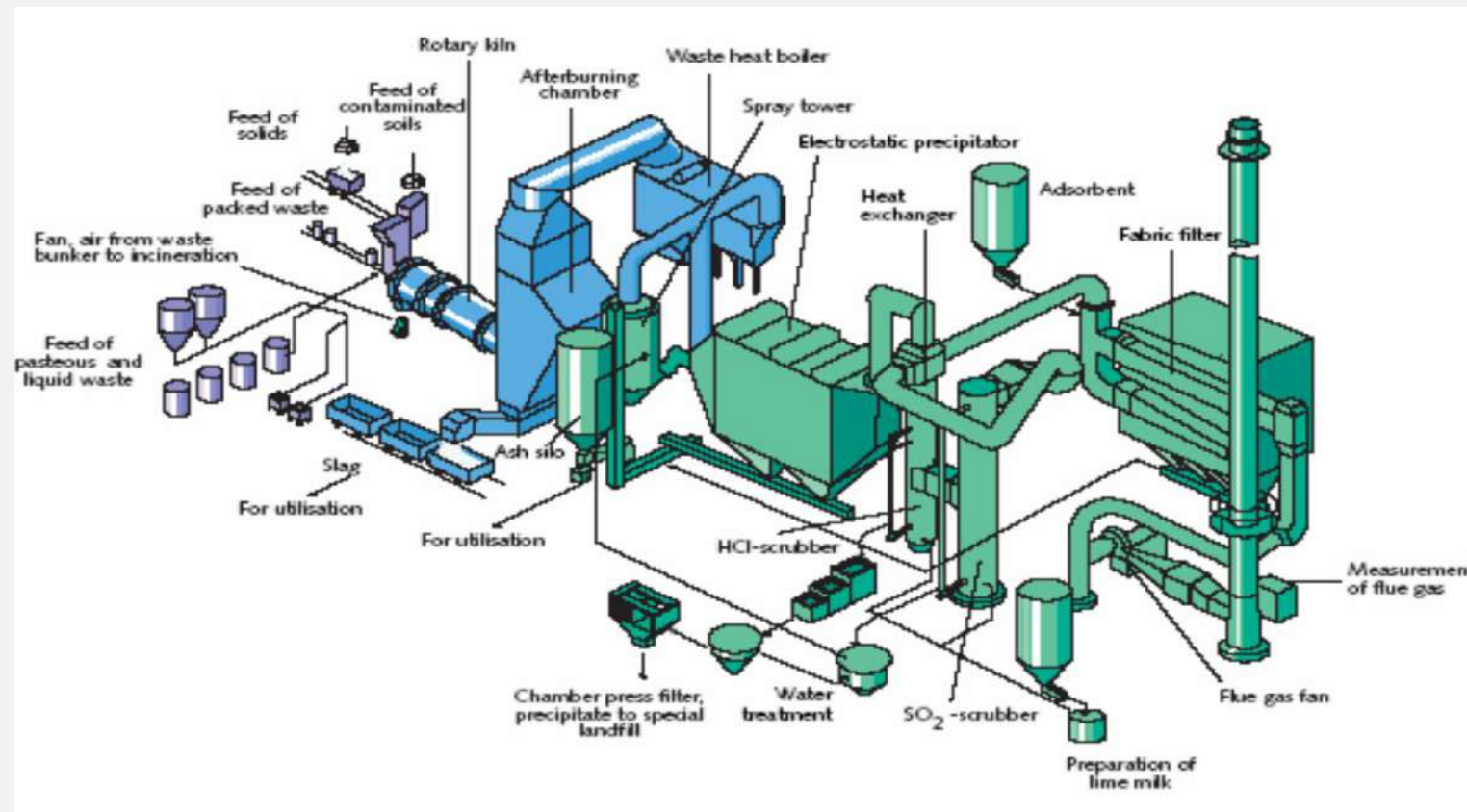

HIGH TEMPERATURE INCINERATION PLANT – LAY OUT 2

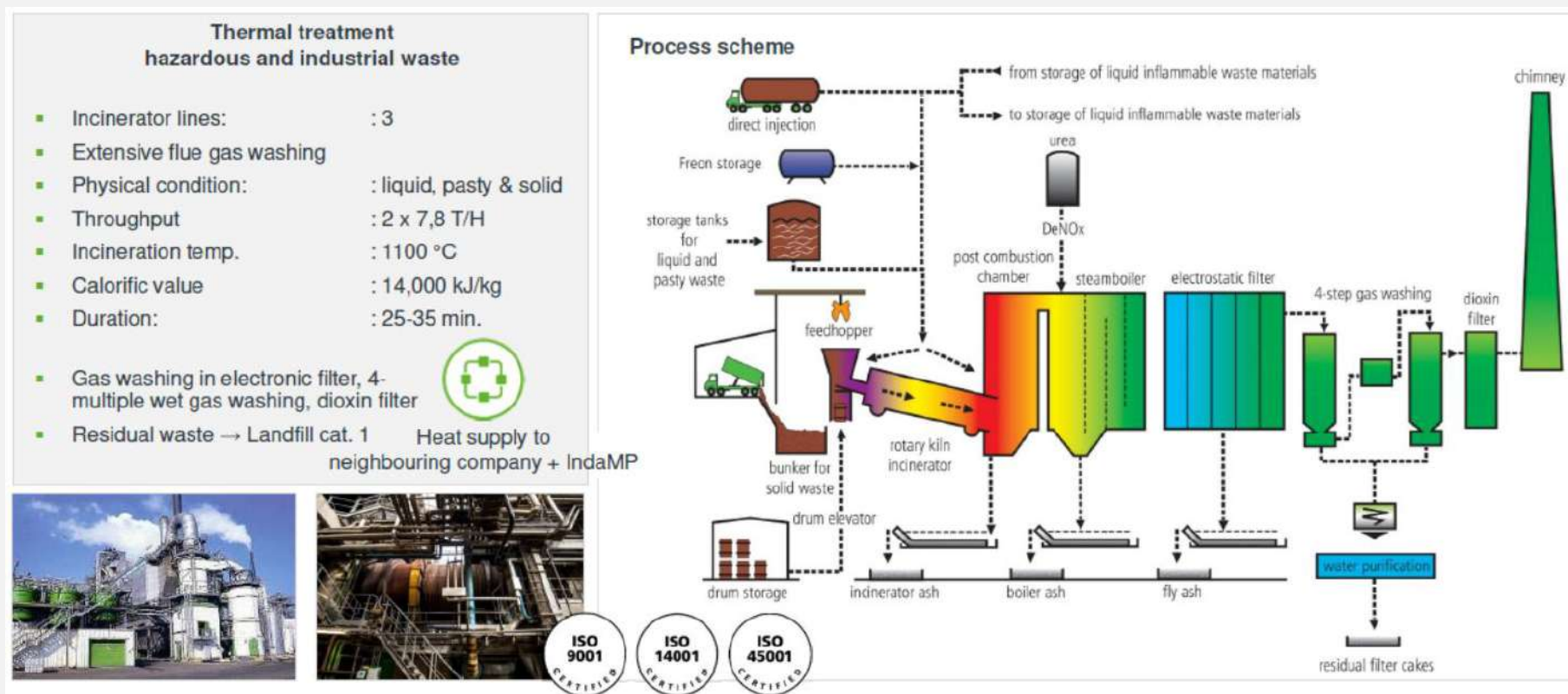

Source: SARPI PCB

NON EXAUSTIVE LIST OF HIGH TEMPERATURES DESTRUCTION PCB PLANTS IN EUROPE

COUNTRY	REMARKS
FRANCE	
ITALY	Only liquids < 500 mg/kg
SPAIN	Limitation in materials
UK	Limitation in materials/concentrations
BELGIUM	
THE NETHERLANDS	Limitation in materials/concentrations
GERMANY	Limitation in materials/concentrations
SWITZERLAND	
POLAND	Limitation in materials/concentrations
ROMANIA	Limitation in materials/concentrations
SWEDEN	

DESTRUCTION PROCESSES – PLASMA ARC

PLASMA ARC

Plasma system technologies use a Plasma Arc device to destroy PCBs.

- Temperatures reach up to 10,000 °C for PCB destruction (**pyrolysis**).
- Plasma Arc is form of electrical discharge via a gas. Electrical energy is converted to thermal energy which ionizes gas molecules.
- Works well with liquids.
- Small volumetric footprint.

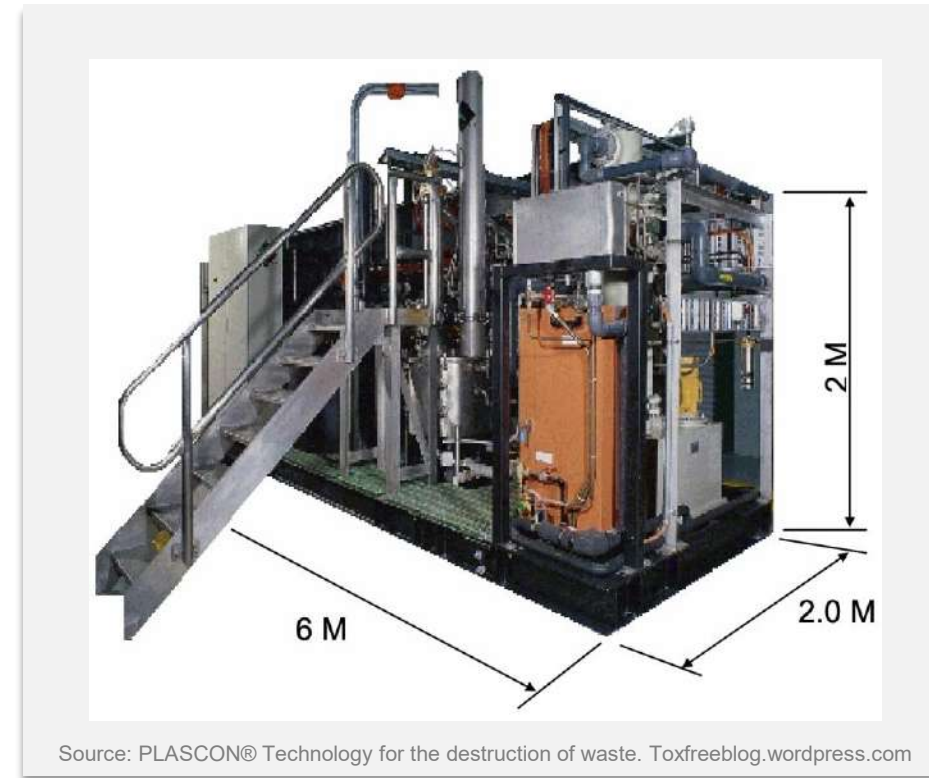

DESTRUCTION PROCESSES – IN-SITU VITRIFICATION (ISV)

IN-SITU VITRIFICATION (ISV)

In-situ Vitrification (ISV) is a commercially available mobile technology used for contaminated site remediation and waste treatment.

ISV involves the electric melting of soil/earth materials at high temperatures by destroying organic contaminants and permanently immobilizing non-volatile inorganic contaminants in a glassy, rock-like vitrified product.

- Destruction efficiency (DRE) as high as 99.9999%.
- Typically operates in the range of 1,600 to 2,000 °C for most earthen materials.
- Electricity flows through the starter path, which heats up and causes the surrounding media to melt.



Source: PCB Destruction Technologies Winston Lue USEPA/OLEM/ORCR/PIID/PB December 7, 2016

DESTRUCTION PROCESSES – IN-SITU VITRIFICATION (ISV)

IN-SITU VITRIFICATION (ISV)

Advantages

- Applicable to all soil types.
- Destruction efficiency (DRE) > 99.9%
- Can achieve treatment rates of up to 150 tonnes per day.
- High concentrations of contaminants, 10-20 wt%.
- In situ process (does not require excavation and handling).

Disadvantages

- Requires a back-up off-gas treatment system and a diesel-powered generator.
- Requires a source of potable water to support process operations.
- ISV requires either soil as the treatment media (melt).
- Sites must be characterized to ensure that there are no high integrity sealed containers.
- Relatively high operations cost for smaller projects.

DESTRUCTION PROCESSES – IN-SITU VITRIFICATION (ISV)

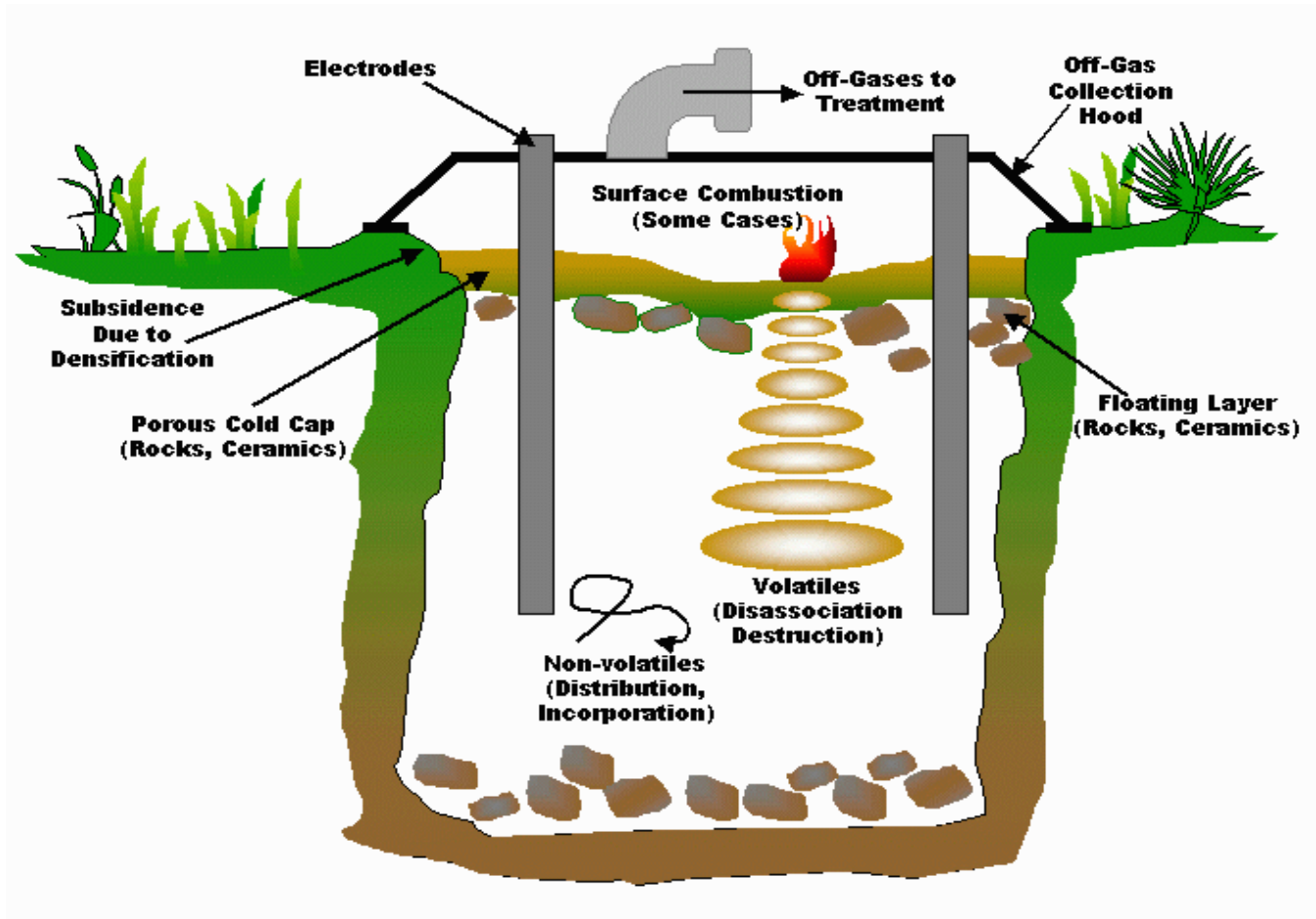

Source: PCB Destruction Technologies Winston Lue
USEPA/OLEM/ORCR/PIID/PB December 7, 2016

DECONTAMINATION PROCESSES – AUTOCLAVING

AUTOCLAVING

Autoclaving is a well-established technology that has been around for many years now. It is a solvent decontamination process that removes PCBs from contaminated material.

Materials from the transformer are autoclaved, and after decontamination various metals and alloys, such as: copper, steel and aluminium are sent to the metals recycling industry.

- Autoclaving works in combination with incineration (wood, paper, ever oil). DRE = 99.999%
- Transformers and capacitors can be decontaminated easily.
- Needs large quantities for origin country installation.
- Operators require a lot of expertise.
- Autoclaving plants are very mobile.
- Utilities are widely availability.



Cores in Autoclaves
Source: Capo A., BRS/UNITAR Regional PCB
Webinar (2025). <https://pcb.unitar.org/webinar-series/regional/webinar-3/>

DECONTAMINATION PROCESSES – AUTOCLAVING

AUTOCLAVING

Advantages

- Excellent decontamination standard (to Non-Destructive Testing, or NDT).
- Metals and alloys can be recovered.
- Recycling revenue exceeds the autoclaving costs.
- Vast cost reduction to disposal costs for PCBs, if done on-shore.
- Low in emissions.

Disadvantages

- Requiring personnel with expertise to run in origin country due to plant complexity.
- Requires large amounts of waste to justify location in origin country (more than 2000 tonnes).
- Requires large amounts of solvent initially although solvent is recovered during the process.

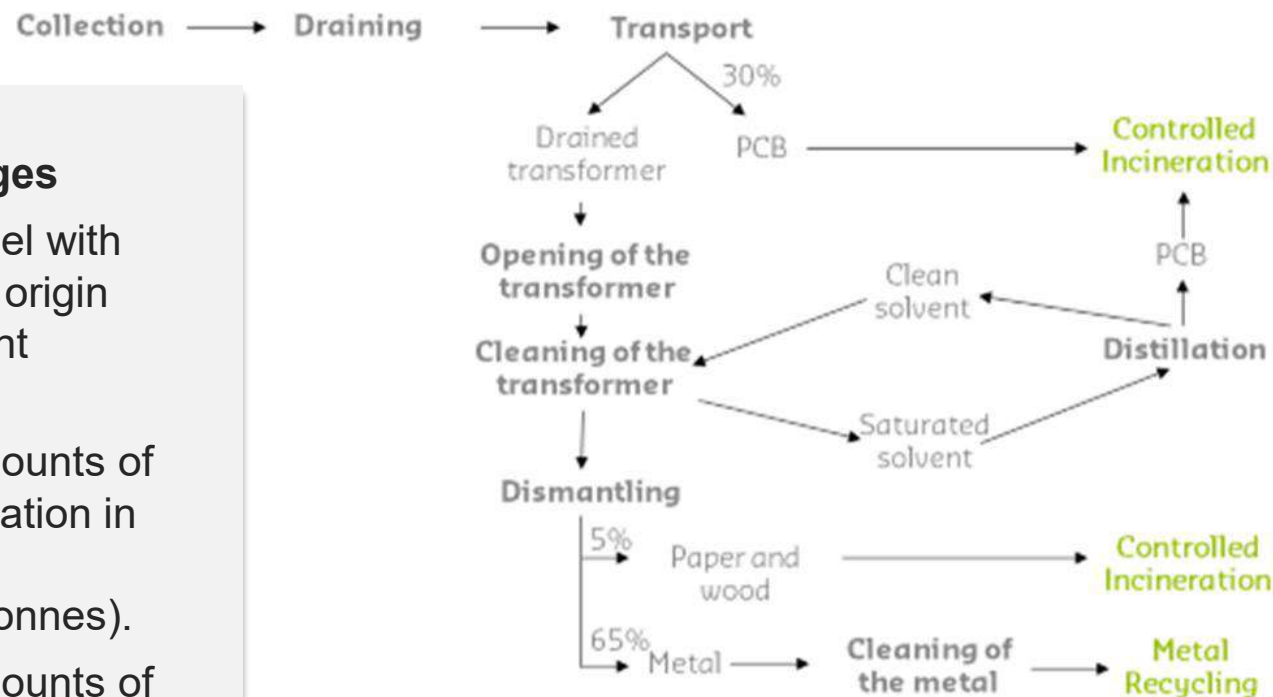

Source: Capo A., BRS/UNITAR Regional PCB Webinar (2025).
<https://pcb.unitar.org/webinar-series/regional/webinar-3/>

DECONTAMINATION PROCESSES – AUTOCLAVING

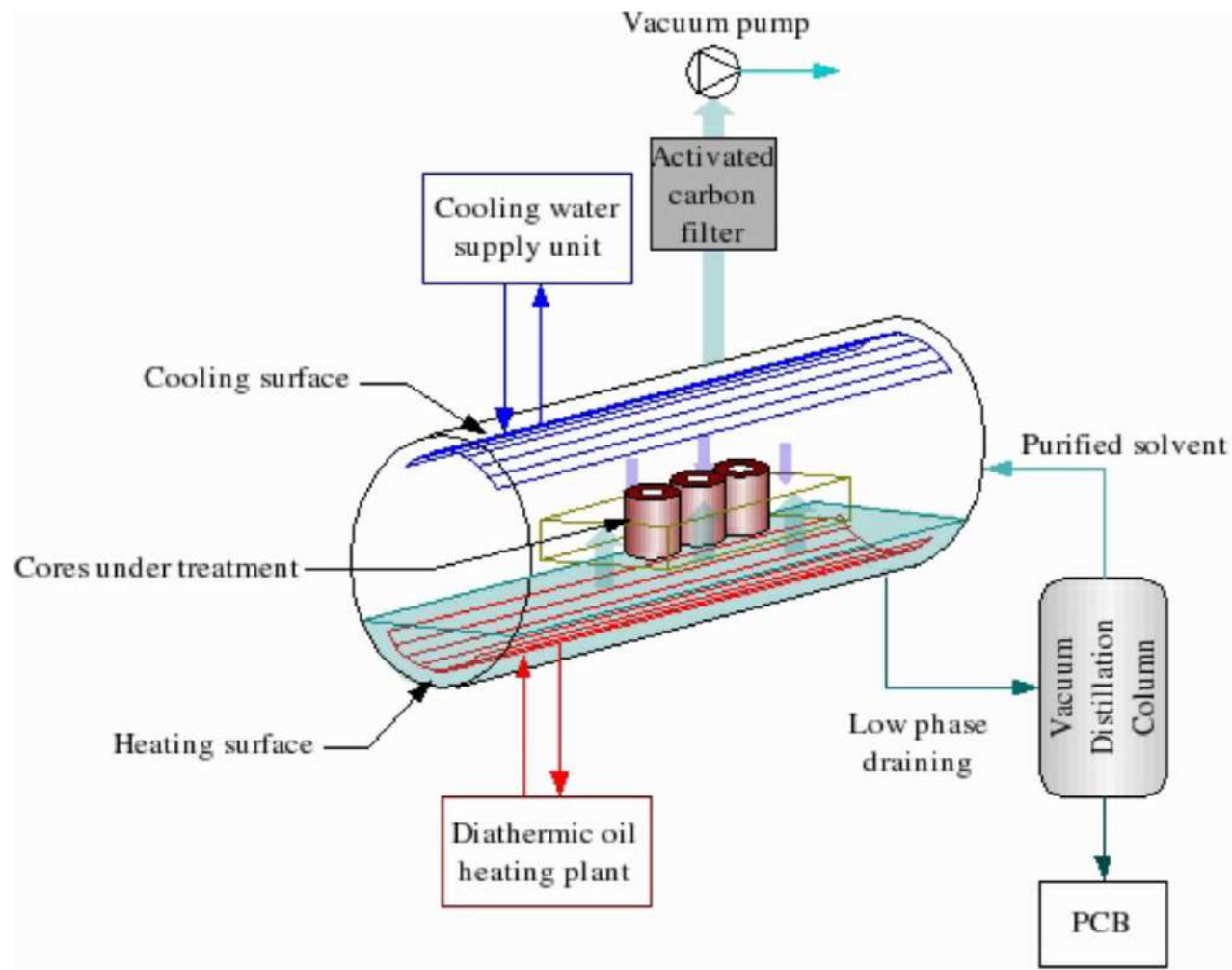

DECONTAMINATION PROCESSES – AUTOCLAVING

AUTOCLAVING

Solvent washing is done in the autoclave – under vacuum to prevent vapors from escaping – to decontaminate the metal parts of the transformers (copper, ferrosilicon, tanks, bolts).

It can be applied for materials contaminated to any PCB concentration, but it is specially designed for equipment contaminated with pure PCB.

- Autoclaving allows us to reach $<10 \mu\text{g}/100 \text{ cm}^2$.
- Solvents used are trichlorethylene or perchlorethylene, either as a hot (60 °C) or cold liquid and as vapors.
- Stills separate the askarel or PCB oil from the solvent, allowing us to reuse it both.
- The distillate bottoms are exported



DECONTAMINATION PROCESSES – AUTOCLAVING

AUTOCLAVING

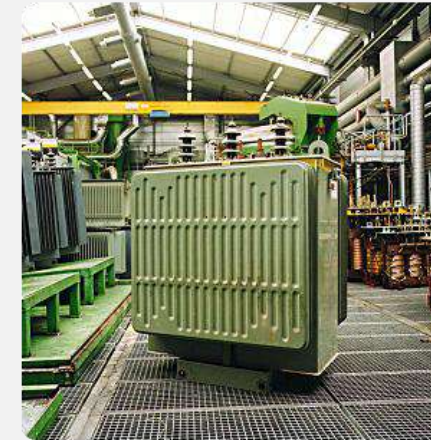
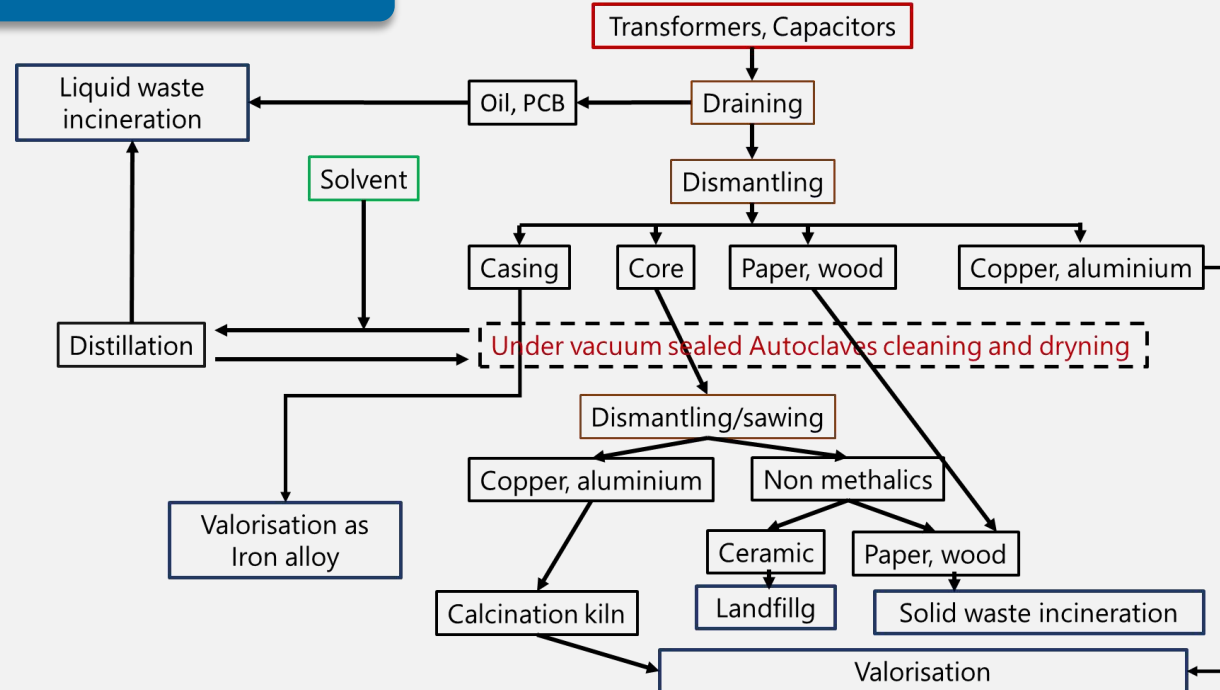

Separation of cores and casings.
Source: Capo A., BRS/UNITAR Regional PCB Webinar (2025). <https://pcb.unitar.org/webinar-series/regional/webinar-3/>

NON EXHAUSTIVE LIST OF PCB DECONTAMINATION AUTOCLAVE-BASED STATIONARY FACILITIES IN EUROPE

COUNTRY	REMARK
FRANCE	
ITALY	Foreign Waste Acceptance Limitations
SPAIN	
UK	Small capability
BELGIUM	
THE NETHERLANDS	
ROMANIA	No Foreign Waste Accepted

The total capability is estimated up to 10.000 tons/year (potential) that is sufficient for current European needs and allowing import from other continents

Source: Capo A., BRS/UNITAR Regional PCB Webinar (2025). <https://pcb.unitar.org/webinar-series/regional/webinar-3/>

DECONTAMINATION PROCESSES – DECHLORINATION

DECHLORINATION

Dechlorination is based on metalorganic reactions with alkali metal or an alkali metal oxide or hydroxide reagents.

- The chlorine content is converted into inorganic salts, which can in turn be removed from the organic fraction by filtration.
- Dechlorination treat wastes up to 10 % PCB (in 2 h).
- The key to the process is the hydrogen donor with an oxidation potential low enough to produce nucleophilic hydrogen in the presence of base sodium hydroxide (NaOH) at low temperatures.



Source: Overview of PCB disposal technologies – Carlo Lupi – UNIDO consultant

DECONTAMINATION PROCESSES – DECHLORINATION

DECHLORINATION

Advantages

- One-step destruction of PCBs and POPs.
- Simple process with very small emissions.
- Well-established technology.
- Small facility footprint.
- Mobile/Stationary.
- Treats big size transformers
- In life assests.
- Online option
- Low-cost
- Oil recovered

Disadvantages

- Requires solvent extraction or other pretreatments with capacitors and transformers.
- Treatment duration
- Daily productivity
- Limited efficiency on some PCTs/PCBTs
- Reagents wasted
- Medium risk of fire for Na/K/Li
- There is a need of some electromechanics knowledge

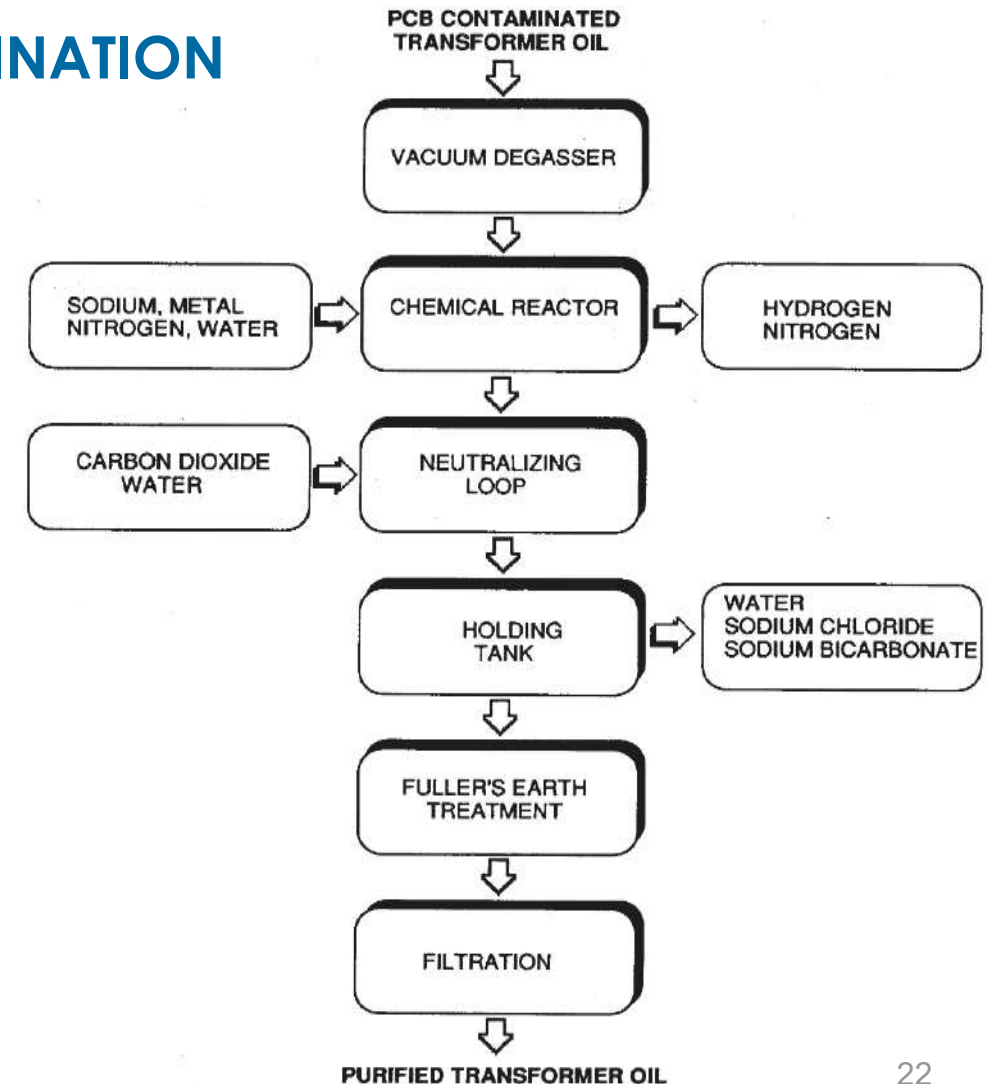

DECONTAMINATION PROCESSES – DECHLORINATION

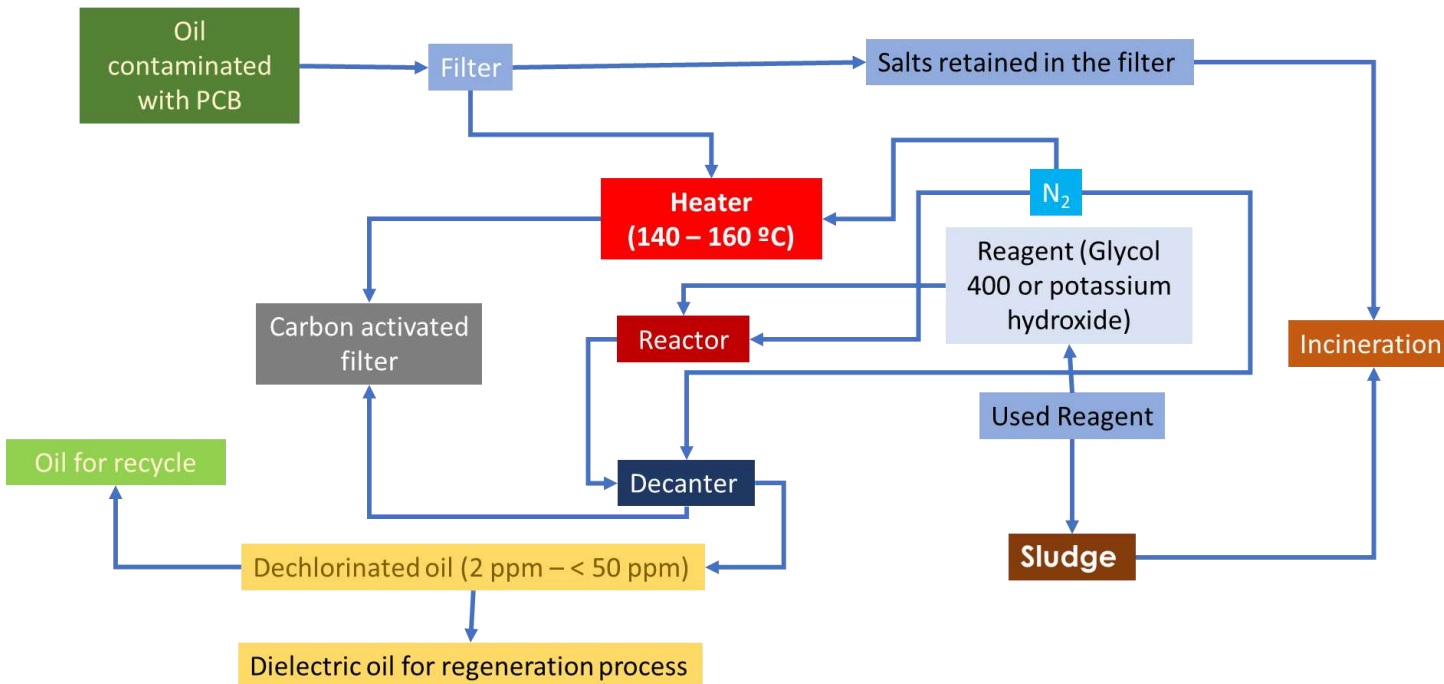

DECONTAMINATION PROCESSES – DECHLORINATION/ALKALI-METAL-REDUCTION

Example: Canadian Mobile Unit with direct operation mode with transformer

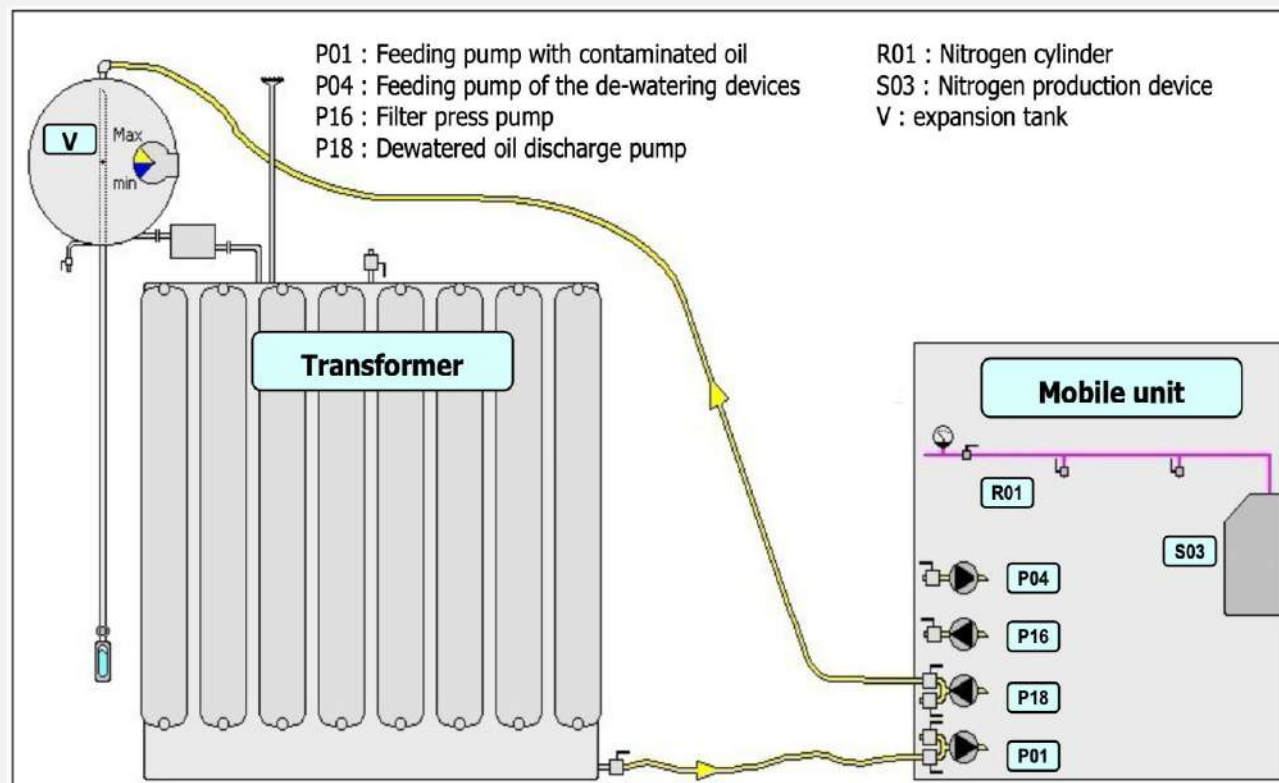

DECONTAMINATION PROCESSES – DECHLORINATION/ALKALI-METAL-REDUCTION

Example: Canadian Mobile Unit with indirect operation mode with transformer using intermediary oil tank

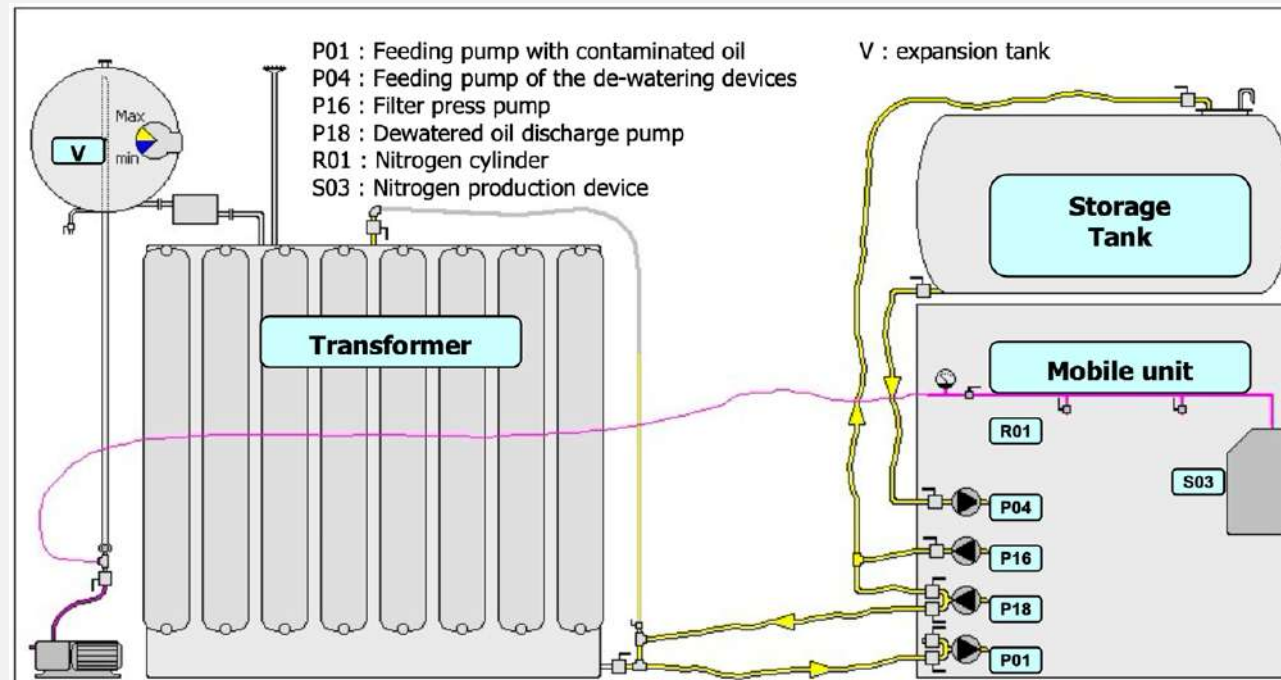

NON EXHAUSTIVE LIST OF PCB DECONTAMINATION AUTOCLAVE-BASED STATIONARY FACILITIES IN EUROPE

COUNTRY	REMARK
FRANCE	
ITALY	Foreign Waste Acceptance Limitations
SPAIN	
UK	Small capability
BELGIUM	
THE NETHERLANDS	
ROMANIA	No Foreign Waste Accepted
<p>The total capability is estimated up to 10.000 tons/year (potential) that is sufficient for current European needs and allowing import from other continents</p>	

Source: Capo A., BRS/UNITAR Regional PCB Webinar (2025). <https://pcb.unitar.org/webinar-series/regional/webinar-3/>

NON EXHAUSTIVE LIST OF PCB DECONTAMINATION DECHLORINATION-BASED MOBILE PLANTS MANUFACTURERS IN EUROPE

COUNTRY	REMARK
FRANCE	Not operational
ITALY	Not operational
SPAIN	
UK	Only for very low contaminated oil
NORTH MACEDONIA	
TURKEY	
AZERBAIJAN	
Plants in Italy, North Macedonia, UK, Turkey use PPG, PPEG tech	
Plants in France, Spain, Azerbaijan Na based tech	

Source: Capo A., BRS/UNITAR Regional PCB Webinar (2025). <https://pcb.unitar.org/webinar-series/regional/webinar-3/>

DECONTAMINATION PROCESSES – ECO LOGIC PROCESS

ECO LOGIC PROCESS

The ECO Logic Process is a gas reduction process using high temperature hydrogen as a reducing agent to destroy PCBs.

- Temperatures reach over 850 °C.
- Hydrogen combines with PCBs in a reduction reaction to form methane and hydrogen chloride.
- This chemical reaction is enhanced by the presence of water, which acts as a reducing agent and as hydrogen source.
- The use of molecular hydrogen requires temperature of 350°C and high pressure.



Overview of PCB disposal technologies . Source: Carlo Lupi – UNIDO consultant

DECONTAMINATION PROCESSES – ECO LOGIC PROCESS

ECO LOGIC PROCESS

Advantages

- Low in emissions.
- Treats all chlorinated molecules.
- Complete destruction of PCBs and POPs.
- Converts chlorinated compounds into usable fuel.

Disadvantages

- Large fixed plant (mobile and portable units available).
- Use of molecular hydrogen.

THE HYDRODEC PROCESS

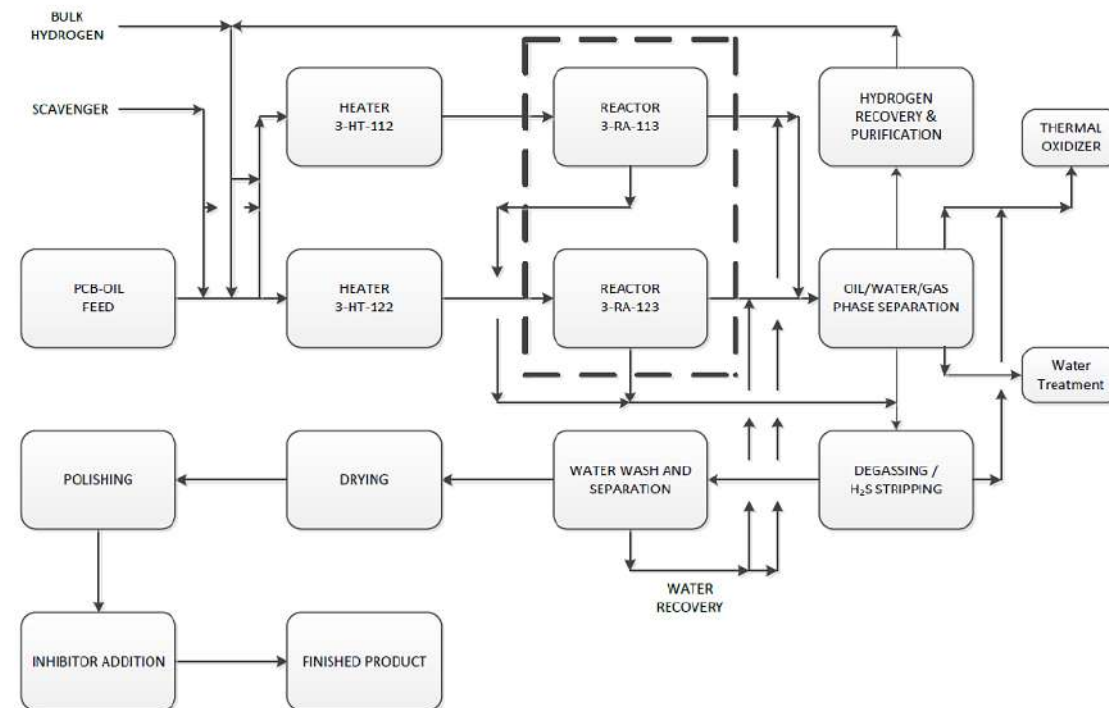

DECONTAMINATION PROCESSES – ECO LOGIC PROCESS

PCB GONE

In-service treatment of transformers is possible using dechlorination processes.

- Fluids are recirculated through the treatment system until the residual PCB concentrations are below required levels of < 2 ppm.
- Recirculation of fluid through the transformer largely flushes the PCBs from the transformer windings and other internal components.
- Treated oil is suitable for continued use.
- Process uses a complex organosodium reagent.
- Within the reaction tank, the reagent immediately reacts with PCBs and all chlorinated hydrocarbons to form sodium chloride and a polyphenylene polymer.
- The reagent reacts to form sodium salts, which are then present in the oil as an insoluble sludge.



Source:
Overview of PCB disposal technologies – Carlo Lupi – UNIDO
consultant

DECONTAMINATION PROCESSES – ECO LOGIC PROCESS

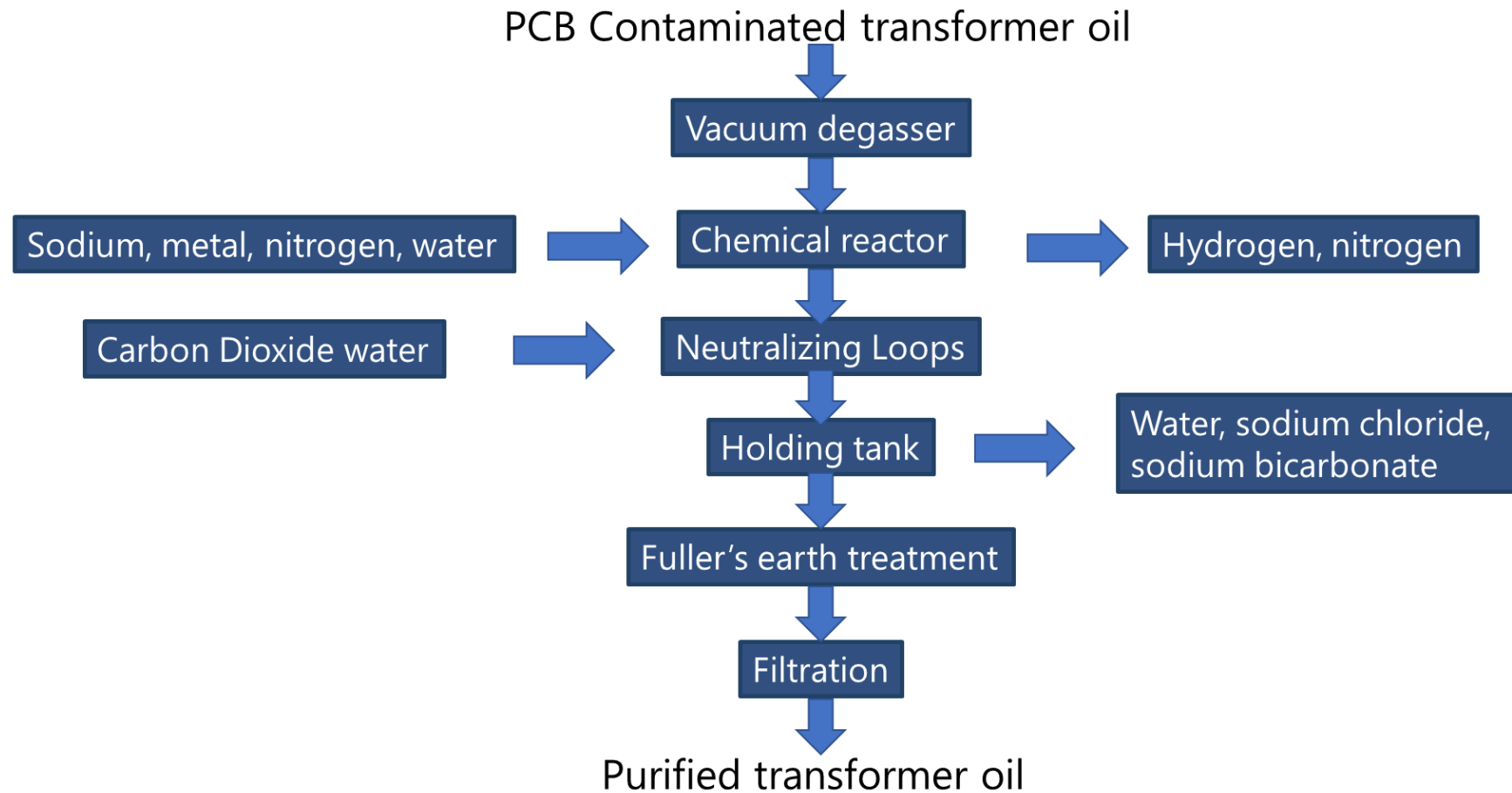

DECONTAMINATION PROCESSES – ECO LOGIC PROCESS

PCB GONE

Advantages

- Cost-effective for low levels of contamination.
- PCB Gone is a portable process.
- Minimal in emissions.
- Low temperature system.
- Treats in-service transformers.

Disadvantages

- Requires gained approval for portable systems.
- Not appropriate for pure PCB transformers.
- Not applicable for capacitors.
- Collected PCB must still be destroyed.

DECONTAMINATION PROCESSES – ECO LOGIC PROCESS



Source: Kioshi Peru S.A.

EMERGING TECHNOLOGIES

BIOREMEDIATION

- Use of micro-organisms to break down organic compounds that contaminate the soil.
- The key to the process is the identification of an appropriate organism to perform this bioremediation process.
- The process need good control of temperature and oxygen levels and requires food sources so that successful application can be achieved.
- Good solution for soil with low concentration of PCB.

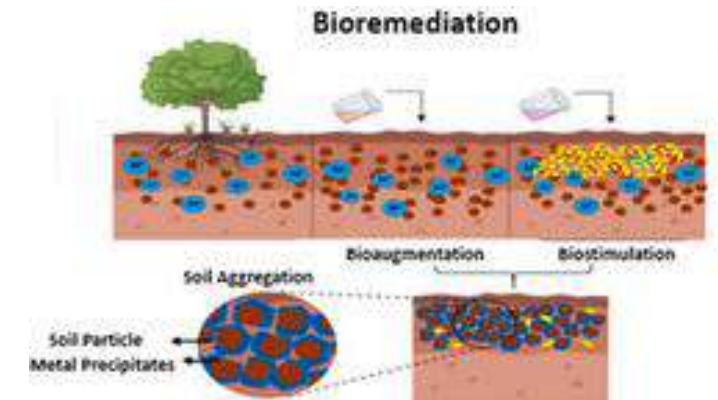

Source: Petrillo, A., Fraternali, F., Acampora, A., Di Chiara, G., Colangelo, F., & Farina, I. (2025). Innovative Solidification and Stabilization Techniques Using Industrial By-Products for Soil Remediation. *Applied Sciences*, 15(7), 4002. <https://doi.org/10.3390/app15074002>

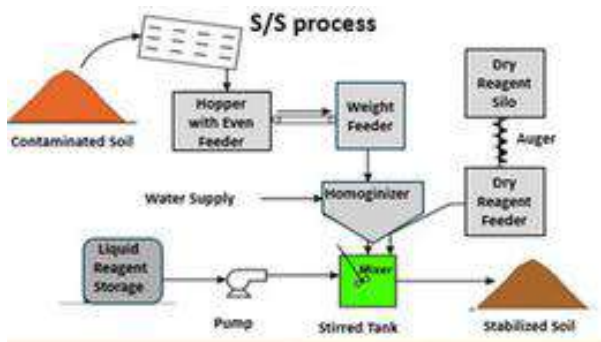

Source: Petrillo, A. et al (2025).

SOLIDIFICATION AND STABILIZATION

- These technologies look for the micro- and macro-encapsulation of PCBs by limiting their mobility or to transfer them to another matrix.

EMERGING TECHNOLOGIES

SOIL WASHING

Soil washing is a technique leaching the PCB from the soil by using caustic agents such as sodium hydroxide (NaOH).

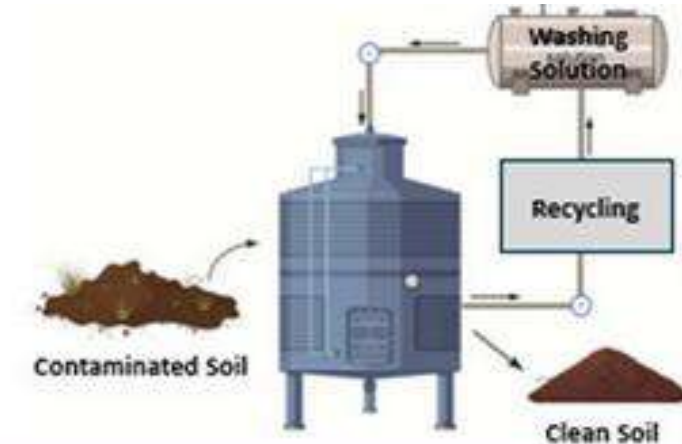

Source: Petrillo, A., Fraternali, F., Acampora, A., Di Chiara, G., Colangelo, F., & Farina, I. (2025). Innovative Solidification and Stabilization Techniques Using Industrial By-Products for Soil Remediation. Applied Sciences, 15(7), 4002. <https://doi.org/10.3390/app15074002>

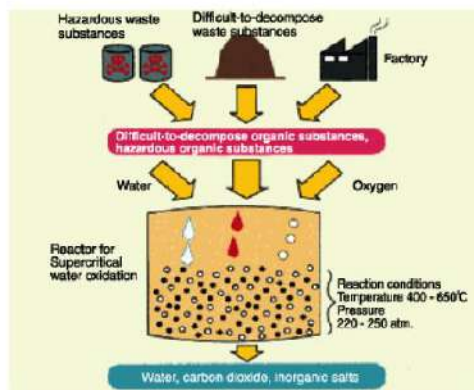

Source: John Vijgen, International HCH and Pesticides Association and Dr.Ir. Ron McDowall, Auckland New Zealand for Secretariat of the Basel Convention (2009)

SUPERCRITICAL WATER OXIDATION

- This technology operates at high temperatures and is a high-pressure system that uses the properties of supercritical water for the destruction of organic compounds.
- An oxidant is injected as required on a heat-based transfer, considering thermal and kinetic requirements.
- The process results in the formation of disposable ash and the emission of gasses.

EMERGING TECHNOLOGIES

GASIFICATION

- Gasification uses low-pressure steam at high temperatures and propagates a thermochemical reaction to vaporize and separate waste into their elemental components. The heated reaction vessel confines a reduction process.
- The thermochemical reaction is a reduction process rather than combustion process.
- There is no reactor stack gas.

CHEMICAL OXIDATION

Chemical oxidation is a process to mineralize PCBs by oxidation using some chemical compounds such hydrogen peroxide (H₂O₂), potassium permanganate (KMnO₄), Oxone, and other reagents.

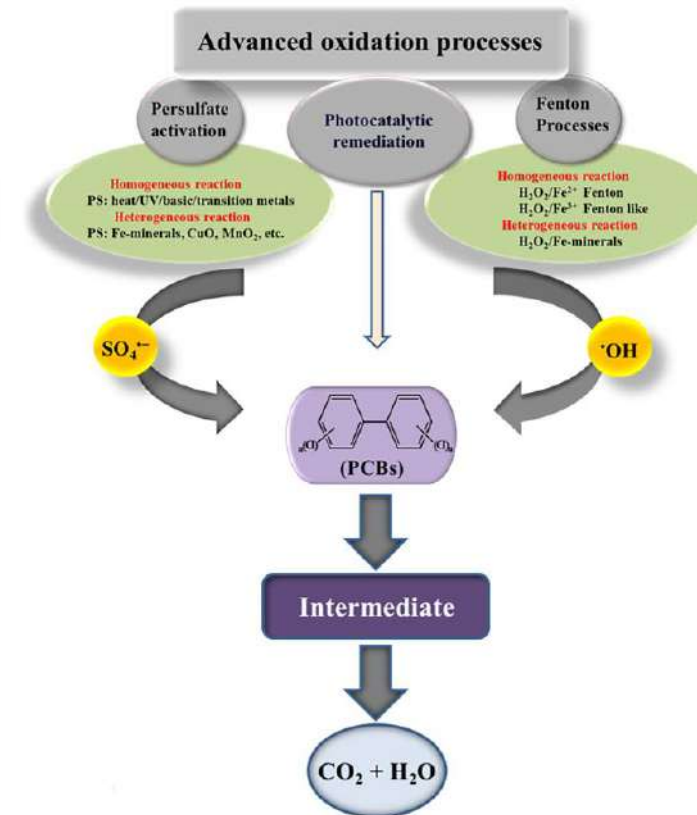

Source: Hashmi, M.Z., Kaleem, M., Farooq, U. et al. Chemical remediation and advanced oxidation process of polychlorinated biphenyls in contaminated soils: a review. Environ Sci Pollut Res 29, 22930–22945 (2022). <https://doi.org/10.1007/s11356-022-18668-3>

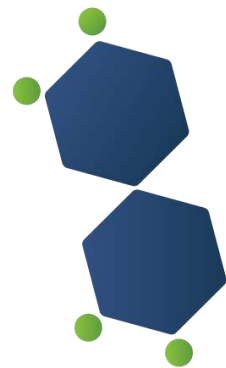

PCB e-Learning Platform

END OF PCB ELIMINATION PART II: ESTABLISHED AND EMERGING TECHNOLOGIES

<https://pcb.unitar.org/>